

# SUBLIFT

BY SWEDE SHIP

75t

THE SAFE, COMPACT, SELF-PROPELLED SUBMERISBLE BOAT CARRIAGE

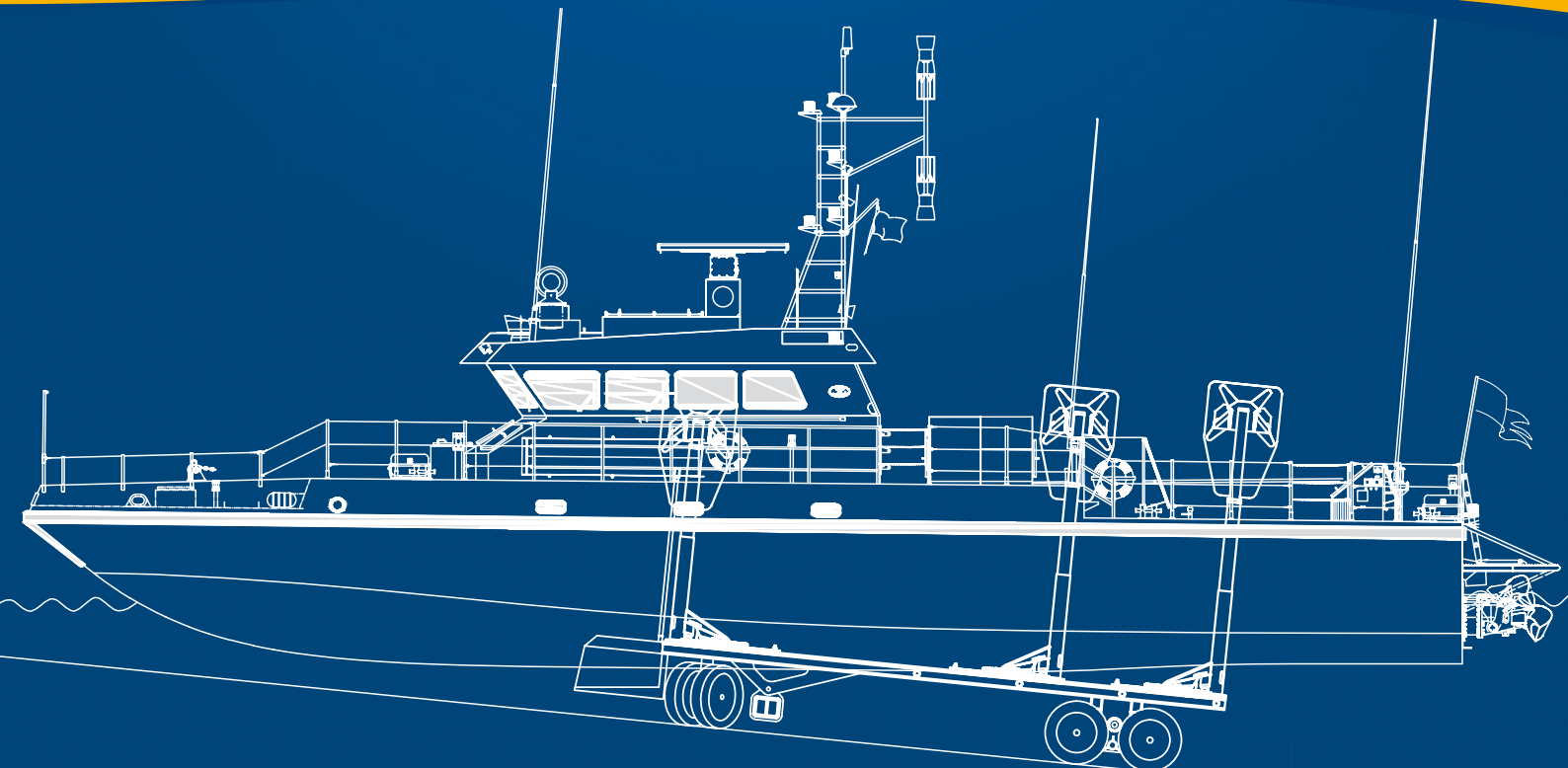

The SUBLIFT 75t is under development based on the experiences made on the 65 and 90 ton models. It is the choice for the yard that service a larger range of boats. It is equipped with double slings on three pairs of hydraulically controlled lifting arms making the carriage most the flexible. The full capacity is 75 ton.

[www.sublift.se](http://www.sublift.se)

# Sublift 75t

Submersible | Flexible width | Remote controlled | Safe and fast

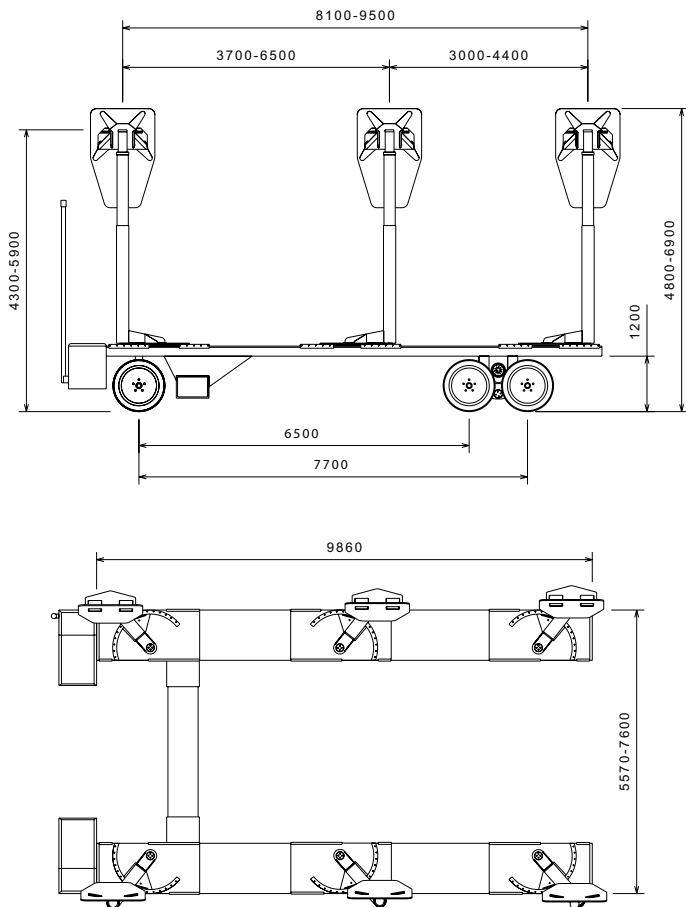

Drawings are subject to change without prior notice.

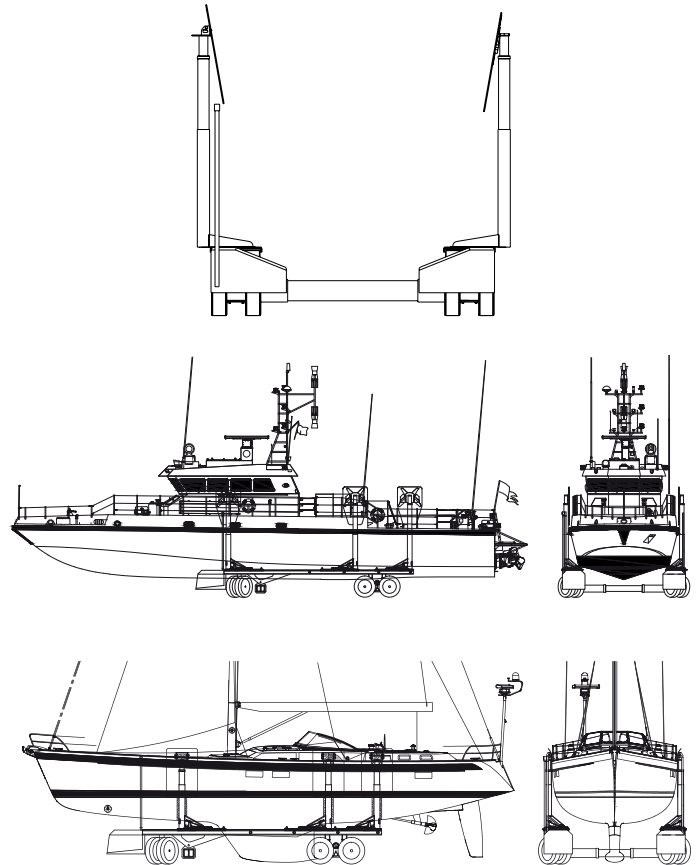

## Sublift 75t - Data

Service weight:	22 000 kg
Max load:	75 000 kg
Max load/sling:	25 000 kg
Highest slope:	1/10

Max side slope:	1/20
Engine:	Kubota 50 kW
Max speed:	5 km/h

- SUBLIFT 75t is designed for a maximum boat load of 75 ton and maximum width of 7.6 m
- All functions are accessible from the remote control
- The double transmission on the bogie axels are fully hydraulic powered
- The aft bogies ensures that the weight is always evenly distributed over the wheel pair
- The hydraulic engine has two gears and stepless speed control with a highest speed of 5 km/h, unladen
- Maximum slipway slope with loaded carriage is 1:10

- Electric sling locks are included as standard
- The lifting arms height, width and axial position are adjustable by hydraulics
- It is possible to lift small boats in the two aft lifting arms
- Actual load on each sling is displayed in the remote control
- The carriage is protected with hot galvanizing and 2-component polyurethane coating
- Wheel axles and hubs have special seals that prevents water penetration

